

Andrzej Jaeschke*, Grzegorz Liškiewicz

Mathematical surge modeling based on the pressure oscillations in the stable operation range of the compressor

*Institute of Turbomachinery, Lodz University of Technology,
219/223 Wólczajska, 90-924 Łódź, Poland*

Abstract

Prevention of surge phenomenon is a very active field of research in last decades. The Greitzer model is the most widely applied mathematical model describing the surge phenomenon. Two parameters that characterize the given compressing system: the Helmholtz oscillator frequency and the so-called B parameter have to be given as the input to Greitzer model. Although those parameters are easy to determine for simplified compressor models, they are extremely hard to predict in case of real industrial compressors. Moreover, in most cases it is impossible to analyse compressor unstable work, which makes this prediction even more speculative. Therefore the method that determines the parameters basing on the compressor stable operation is indispensable. In paper the regularly perturbed Greitzer model based method of predicting the behaviour of a compressor in the unstable operation basing on signals from its stable operation is proposed and discussed.

Keywords: Radial compressors; Surge; Greitzer model

Nomenclature

a_a – speed of sound
 f_h – Helmholtz frequency
 k – throttle constant
 L_c – length of compressor

*Corresponding Author. Email adress: andrzej.jaeschke@p.lodz.pl

L_t	–	length of throttle
\dot{m}	–	mass flow rate
p	–	pressure
S_c	–	cross-section area of compressor
S_t	–	cross-section area of throttle
\hat{t}	–	non-dimensional time coefficient
U_{tip}	–	impeller tip speed
V_p	–	volume of plenum
PR	–	pressure ratio of the compressor
TOA	–	throttle opening are

Greek symbols

Φ	–	non-dimensional mass flow rate coefficient
Ψ	–	non-dimensional pressure rise coefficient
ρ_a	–	as density

1 Introduction

1.1 Unstable phenomena in centrifugal compressing units

When a centrifugal compressor is operating at given rotational speed and the mass flow rate is reduced beyond a certain critical value, the operation of the compressor is no longer stable. As the instabilities can cause a failure of compressor which can cause significant financial losses, it is very important to accurately predict the point where instabilities are likely to occur. Unfortunately, the mechanisms that are responsible for creation and behaviour of instabilities are very complex which makes the prediction difficult. Emmons *et al.* [1] was the first to identify and analyse the nonstable phenomena in the centrifugal compressors. Two main unstable phenomena have been identified: surge and rotating stall. Surge refers to global flow fluctuations in the axial direction. Rotating stall is a phenomenon of the formation of vortex structures which are stationary in a certain rotating frame of reference, so-called stall cells [2]. Those states can be identified as forms of natural fluid oscillation. In stable operation they are fully suppressed, while in the unstable region the damping is not strong enough and rotating stall or surge are likely to appear [3,4].

1.2 Greitzer model of surge phenomenon

In 1976 Greitzer introduced the mathematical model of unstable behaviour of compressing units [5] and confirmed it by experiment [6]. Later a development towards description of the shape of fully-formed transients has been made by

Moore and Greitzer [7,8]. Although Greitzer introduced his model for axial compressors it was also proven to be correct for centrifugal machines [9–12].

Greitzer modeled the compressing system as three interacting elements: compressor, plenum and throttle. The compressing system simplified by Greitzer is presented in Fig. 1. Compressor and throttle are characterized by their lengths L_c and L_t , and areas S_c and S_t , respectively. Plenum is characterized by its volume V_p . Pressure p at each component and mass flow rates (\dot{m}_c and \dot{m}_t) at compressor and throttle are the variables. The subscripts c , t and t indicate components of the compressing system, respectively, compressor, plenum, and throttle. Additional model assumptions are listed below [13,14]:

- flow within pipes is incompressible, inviscid and one dimensional,
- compression in plenum is isentropic,
- temperature is constant in the whole system,
- pressure in plenum is uniform,
- valve is quasi-static,
- gravity forces are neglected.

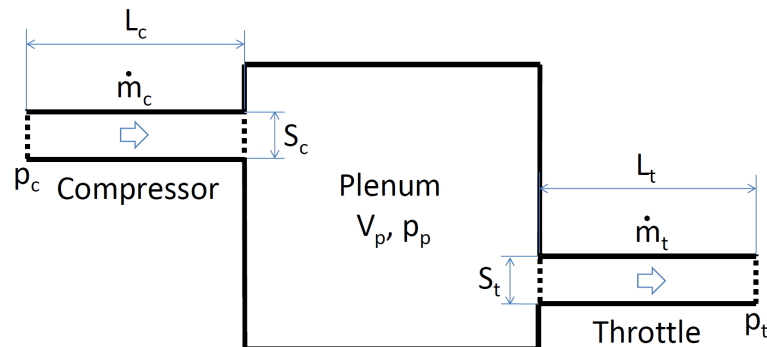

Figure 1: Compressing system in Greitzer model [13].

Greitzer model consists of system of four ordinary differential equations, where first three are derived from conservation of mass and momentum for three components of the system. Fourth equation describes the effect of rotating stall on the system. In case of centrifugal units behaviour of rotating stall phenomena is far too complicated to be accurately approximated by one simple ordinary differential equation. Therefore, for case of centrifugal compressors it is a general practice not to use this equation and use Greitzer model for simulation of only surge phenomenon (not considering rotating stall). The Greitzer model for centrifugal units

in the nondimensional form reads:

$$\frac{d\Phi_c}{d\hat{t}} = B(\Psi_c - \Psi_p), \quad (1a)$$

$$\frac{d\Phi_t}{d\hat{t}} = \frac{B}{G}(\Psi_p - \Psi_t), \quad (1b)$$

$$\frac{d\Psi_p}{d\hat{t}} = \frac{1}{B}(\Phi_c - \Phi_t) \quad (1c)$$

where dimensionless mass flow rate coefficient $\Phi = \frac{\dot{m}}{\rho_a U_{tip} S_c}$ with index corresponding to component of the system, dimensionless pressure rise coefficient $\Psi = \frac{2\Delta p}{\rho_a U_{tip}^2}$ with index corresponding to component of the system, dimensionless time coefficient $\hat{t} = t f_h 2\pi$, model parameters $B = \frac{U_{tip}}{4L_c f_h \pi}$ and $G = \frac{S_c L_t}{S_t L_c}$, here ρ_a denotes gas density, U_{tip} – impeller tip speed, Δp – difference of outlet and inlet pressure of component, f_h is the Helmholtz resonator frequency, given by formula

$$f_h = \frac{1}{2\pi} a_a \sqrt{\frac{S_c}{V_p L_c}} \quad (2)$$

with a_a denoting the speed of sound.

Although the Greitzer model is very simplified and has many questionable assumptions it has been proven to be very efficient tool for surge modeling. Greitzer model is also a base for development of more complicated mathematical surge models [15–17]. Although there were some other attempts to formulate mathematical surge models in the past 40 years, the Greitzer model is still the one most often used [18].

The Greitzer model has one well-known, severe limitation. The parameters: B , G and f_h are very hard to be estimated using only the geometry of the compressing system. Although the meaning of geometrical parameters (e.g., L_c) is clear on the level of Greitzer's simplified compressing system, it is vague for real compressing units. This significantly limits the applicability of the method.

A common practice is to remove the second equation describing the throttle dynamics from the model. This can be done assuming that the length of throttle is negligible and therefore value of G is small, which implies very fast response of throttle. As the time of response is infinitesimal, the second equation can be omitted. This reduces the set of problematic parameters to B and f_h [15]. The necessary parameters were successfully estimated using pressure signals from the surge region [12,19]. Unfortunately, most of machines can not operate in unstable region, so another methodology of estimation of Greitzer model parameters is still to be developed.

1.3 Aim of study

The Greitzer model was proven to be a suitable tool for analysis and prediction of dangerous surge phenomenon in centrifugal compressors. Unfortunately, it is hard to evaluate the necessary parameters for the model using only a geometry of unit. It was shown that it is possible to find those parameters having the pressure signal from the unstable operation, but many machines cannot be operated within the unstable region for safety reasons. Therefore, the authors of this article decided to focus on investigation of possible methods of evaluation of necessary parameters using only pressure signals from stable operation of centrifugal compressor. To realise it the perturbed Greitzer model approach was proposed and compared with previously published experimental signals.

2 Method

2.1 Experimental rig

For validation of proposed mathematical model the experimental results obtained by Liskiewicz *et al.* have been used in [20] as a mean. In the considered research a single stage centrifugal blower DP1.12 was investigated. There were several tests performed on this machine concerning its unstable operation [13,20–22]. The cross-section and main dimensions of the blower are presented in Fig. 2. The air entered the rig through the inlet pipe (A). Then the flow was accelerated in the Witoszynski nozzle (B) [23]. Downstream the nozzle there is the impeller (C). From impeller the flow was entering a vane-less diffuser (D) from where it entered a circular volute (E). A throttling valve was placed at the end of the outlet pipe. The most important dimensions of the test rig are presented in Tab. 1.

The rotor was driven by an asynchronous AC motor (400V/15 kVA). The blower was designed for operation at ambient conditions. The design point of the blower was at mass flow rate $\dot{m} = 0.8$ kg/s and pressure ratio $PR = 1.12$. In this study to avoid impeller damage the blower was operated at lower rotational speed of $f_{rot} = 100$ Hz, with nominal mass flow rate $\dot{m}_n = 0.75$ kg/s and pressure ratio (the ratio of pressure after compression to the pressure at the inlet of the compressor) $PR = 1.08$. Obtained impeller tip speed was equal to $U_{tip} = 103$ m/s. The impeller had $z = 23$ blades which corresponds to blade passing frequency of $f_{BP} = 2.3$ kHz. The volume of outlet pipe was equal to $V_{out} = 0.0968$ m³ that in this setting corresponded to the Helmholtz frequency of $f_H = 11$ Hz [12].

The test stand was equipped with two dynamic subminiature Kulite transducers connected to Iotech Wavebook 516/E data acquisition system. One transducer

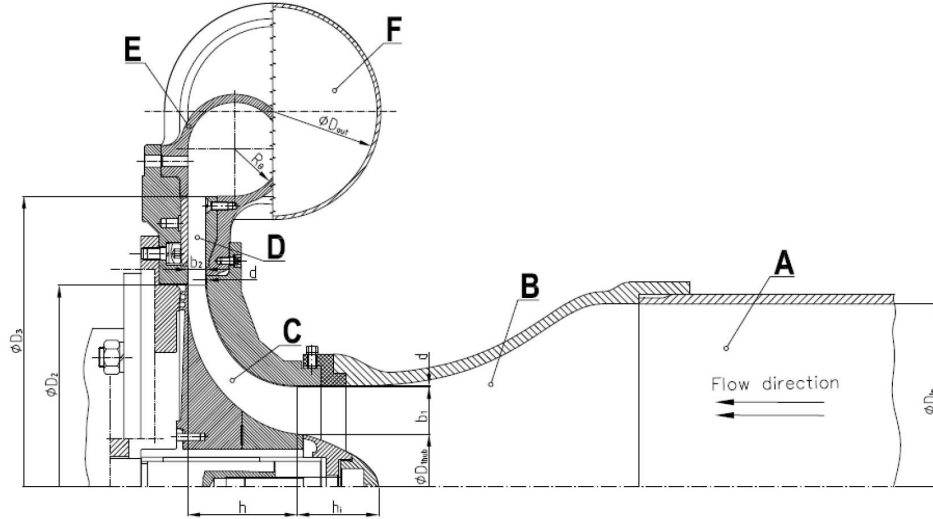

Figure 2: Cross-section of the blower used in the study.

Table 1: Table of most important dimensions of the test rig.

Parameter	Notation	Value
Inlet pipe diameter	D_{in}	300 mm
Rotor inlet diameter at hub	D_{1hub}	86.3 mm
Rotor inlet span	b_1	38.9 mm
Rotor outlet diameter	D_2	330 mm
Rotor outlet span	b_2	14.5 mm
Blade tip gap (constnat along blade)	δ	0.8 mm
Diffuser outlet diameter	D_3	476 mm
Volute tongue gap	δ_g	5 mm
Diameter of outlet pipe / volute outlet	D_{out}	150 mm
Length of the outlet pipe	l	5.5 m
Volume of the outlet pipe	V_{out}	0.0968 m ³

(P_{s-in}) was placed at the inlet of the rig and the other (p_{s-out}) at the volute outlet. Placement of the gauges is presented in Fig. 3. Sampling frequency was equal to 100 kHz. The measurements were done over 20.97 s (2^{21} samples).

Position of the throttling valve placed at the end of outlet pipe was described by dimensionless throttle opening area parameter (TOA). TOA = 0% corresponds

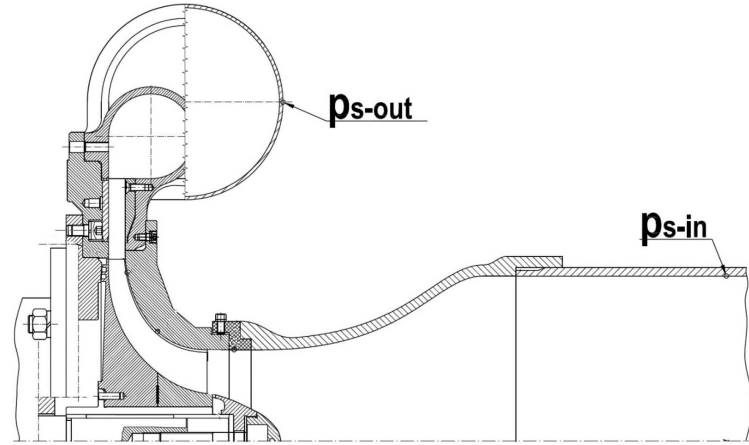

Figure 3: Positions of the pressure gauges in the blower.

to fully closed valve, while TOA = 100% corresponds to fully open valve.

2.2 Compressor modeling with perturbed Greitzer model

The operation of the blower is simulated using the Greitzer model (1) with the second equation omitted. With simplification $\Psi_p = \Psi_t$ resulting from assumption of instant response of the throttle this model reads:

$$\frac{d\Phi_c}{d\hat{t}} = B(\Psi_c(\Phi_c) - \Psi_t), \quad (3a)$$

$$\frac{d\Psi_t}{d\hat{t}} = \frac{1}{B}(\Phi_c - \Phi_t(\Psi_t)). \quad (3b)$$

In the formulas above it was indicated that Ψ_c is a function of Φ_c . This dependency is given by performance curve of compressor at given rotational speed. It was also shown that Φ_t depends on Ψ_t . This dependency is given by the reverse throttle curve. Performance curve of the analysed compressor is according to [19] given by the fourth order polynomial

$$\Psi_c(\Phi_c) = 0.1116\Phi_c^4 - 0.6654\Phi_c^3 + 0.9218\Phi_c^2 + 0.8524. \quad (4)$$

The throttle curve is given by quadratic function [14]

$$\Psi_t(\Phi_t) = k\Phi_t^2, \quad (5)$$

where the throttle constant k was specified in each case to achieve given point of operation. The point of operation was computed from the compressor performance curve knowing the value of mass flow rate attained at the experimental test stand. The values of mass flow rates for given values of TOA coefficient were computed using empirical relation

$$\dot{m} = 0.0943 \text{ TOA}^{0.5758} . \quad (6)$$

The coordinates of point of operation were used as the initial conditions in numerical model.

Obviously, in case of operation in the stable region the Greitzer model is not producing any oscillations. In the real machine, however there are many perturbances pushing the compressor away from its operating point. They are damped in time (as the compressor operates in the stable range) but their presence and the process of their damping (which is not immediate) creates some frequency/amplitude pattern. To capture a trace of this behaviour in the stable region with Greitzer model, an artificial perturbation was added to the pressure value with constant frequency. It was decided to use frequency of $f_p = 100$ Hz which corresponds to frequency of rotation of the rotor and magnitude of perturbation $\delta_\psi = 0.01$. The magnitude is of the same order as the perturbances observed in the oscillation's spectrum of this machine in [20]. Technically, the perturbing was done by dividing the process of solving of the system of ordinary differential equations (3) in time into subproblems of length 0.01 s and perturbing final time solution of previous subproblem before using it as the initial condition for the next one.

In case of both numerical and experimental results the fast Fourier transform (FFT) algorithm [24] was used to allow the spectral analysis of pressure oscillations. Entire analysis was performed on the nondimensional coefficients.

3 Results

3.1 Numerical results

The perturbed Greitzer model was used for simulation of compressor operation at TOA = 4% (deep surge) and TOA = 50% (stable operation). The Greitzer model input parameters were taken from [19] where they were calculated to best fit the pressure signals from deep surge the values were $B = 0.725$ and $f_h = 11.43$ Hz. It should be noted that this value is slightly different than one obtained analytically according to [12]. At TOA = 4% the compressor is expected to work in highly

unstable region, while TOA = 50% corresponds to fully stable operation. Results after the Fourier transform done by the means of the FFT algorithm are presented in Figs. 4 and 5. In the unstable operation a large peak close to the Helmholtz frequency can be observed, interestingly there is a slight amplification in the vicinity of this value also in the stable operation. Therefore, the investigation of positioning in the spectrum of the maximum oscillation amplitude and its value for different values of TOA was performed. To avoid finding a maximum oscillations at 100 Hz that corresponded to added perturbation the search interval was limited to frequency $f < 90$ Hz. Figures 6 and 7 present the behaviour of the value and positioning in the spectrum of the maximum oscillation amplitude for variable values of B while Figs. 8 and 9 depict the situation in case of variable f_h . Lines marked with X in Figs. 6–9 correspond to $B = 0.7$ and $f_h = 11$ which are close to the values applied by Grapow in [19].

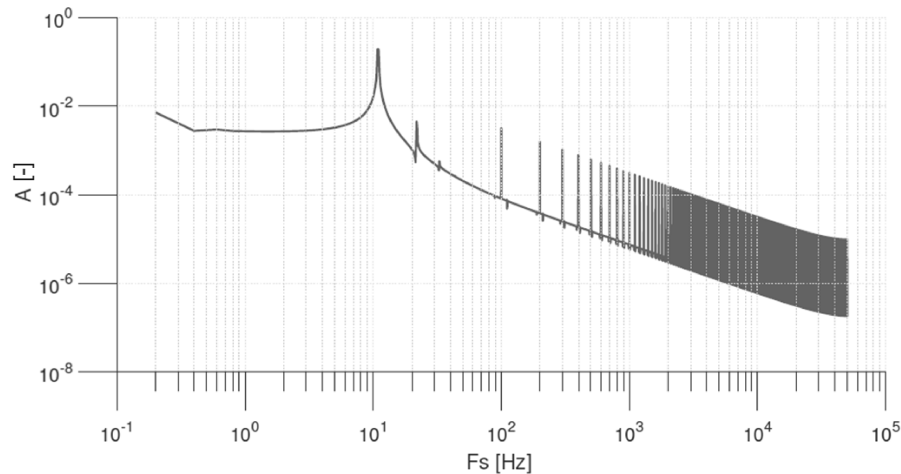

Figure 4: The frequency spectrum of perturbed Greitzer model with $B = 0.725$, $f_h = 11.43$ Hz, and TOA = 4% obtained by means of FFT algorithm (A – amplitude, Fs – frequency).

3.2 Experimental results

Figures 10 and 11 present the non-dimensionalized experimental signals for TOA = 4% and TOA = 50%, respectively, after application of the FFT algorithm. Figure 12 presents the values of the largest amplitudes observed in experiment for variable TOA. In Fig. 13 the positioning of maximum oscillation amplitude versus the values of TOA is presented together with the general trend after averaging the result on span of 10 values. To avoid strong noises at higher frequencies, the

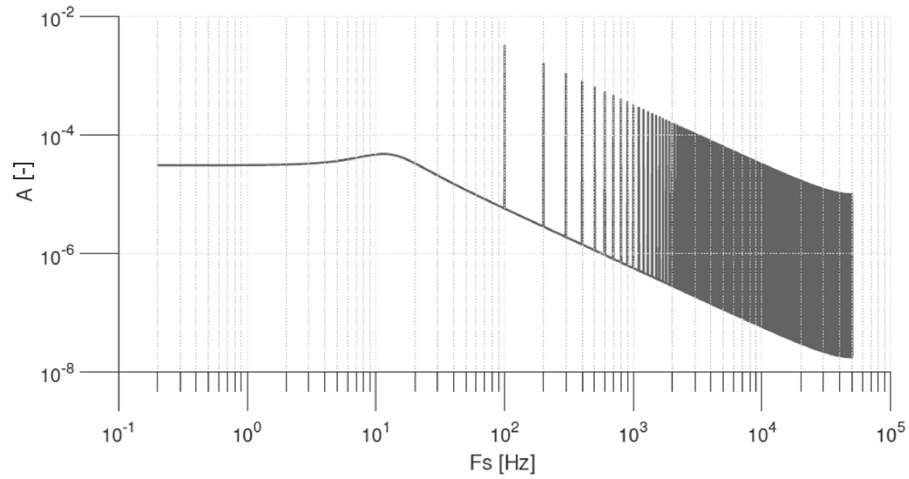

Figure 5: The frequency spectrum of perturbed Greitzer model with $B = 0.725$, $f_h = 11.43$ Hz, and TOA = 50% obtained by means of FFT algorithm (A – amplitude, F_s – frequency).

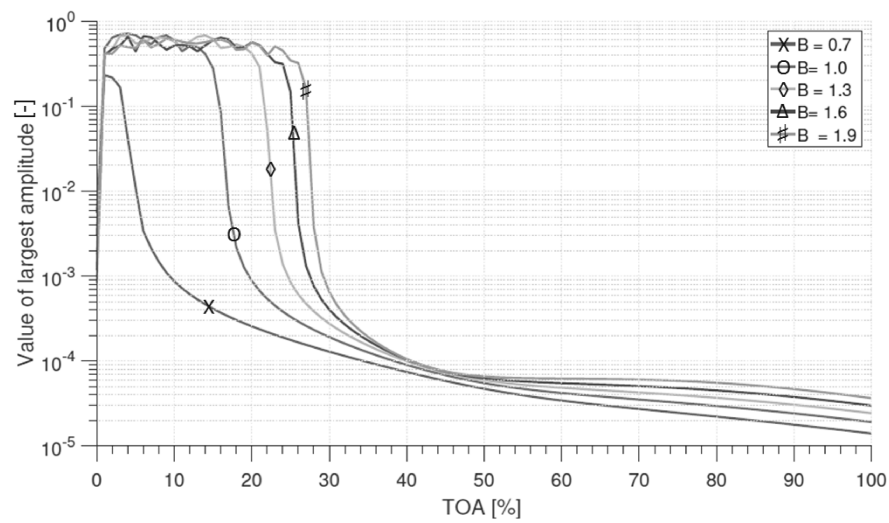

Figure 6: The largest observed amplitude versus TOA for $f_h = 11.43$ Hz and different values of B .

maximum oscillations positioning was searched only in the region $9 \text{ Hz} < f < 20 \text{ Hz}$. Results presented in Figs. 12 and 13 are compared with corresponding numerical results (for $B = 0.725$ and $f_h = 11.43$ Hz).

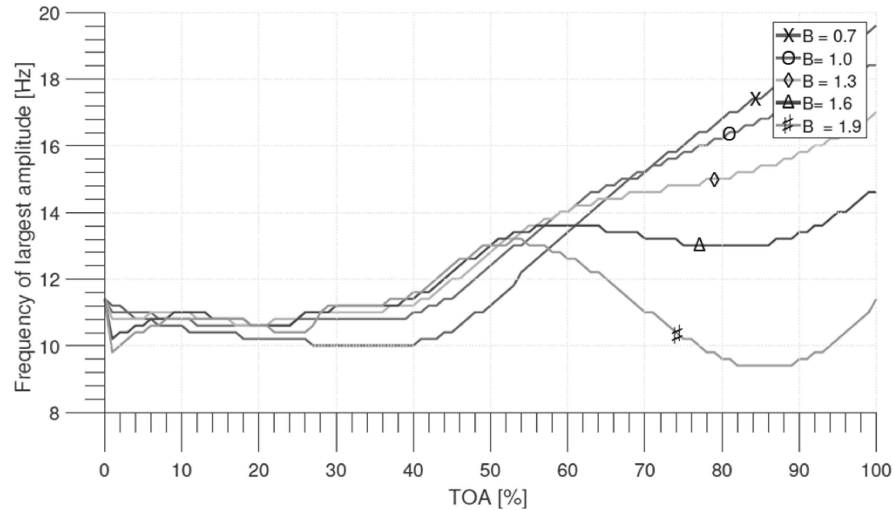

Figure 7: The frequency corresponding to the largest observed amplitude versus TOA for $f_h = 11.43$ Hz and different values of B .

4 Discussion

4.1 Investigation of the model

Application of the perturbed Greitzer model to the case of operation in the unstable region gave expected results: there was a large peak at the frequency slightly lower than the one corresponding to assumed f_h . For larger value of TOA corresponding to stable operation there was also a small amplification present at the slightly higher frequency. This was caused by the fact that according to the Greitzer model, even for very stable systems the damping of oscillations is not immediate, so for the regular perturbation it leaved a track in the oscillation spectrum. Similar effect was observed in experimental study [20]. Importantly, the amplitude values were of significantly lower magnitude for stable operation than in case of unstable operation. The peak in both spectra at $f = 100$ Hz was caused by the regular perturbation itself. It was also followed by its harmonics.

The further analysis of positioning of the maximum amplitude in the spectrum was performed. It was shown that the frequency is decreasing in the region of low TOA values and then it starts to significantly increase with increasing TOA. This behaviour can be very useful for determining the f_h parameter using pressure signals from stable operation of compressor. It was also observed that the

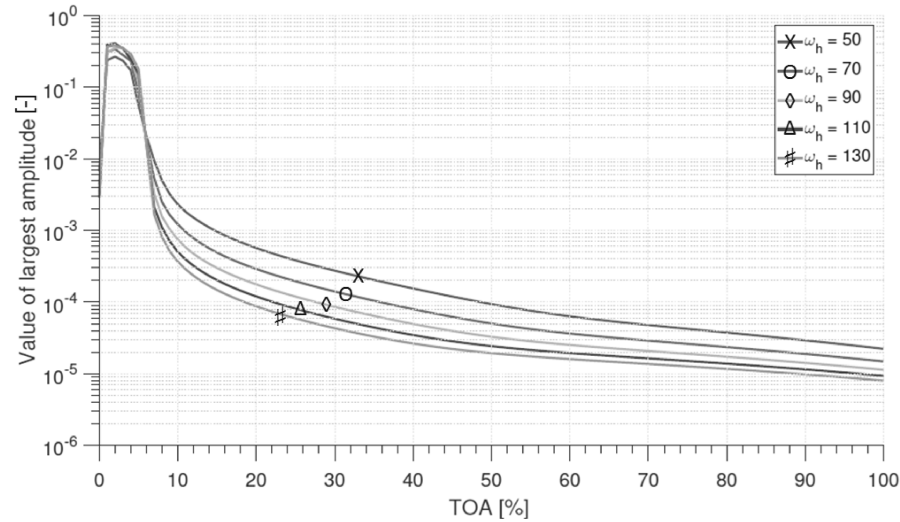

Figure 8: The largest observed amplitude versus TOA for $B = 0.725$ and different values of ω_h , ($w_h = 2\pi f_h$).

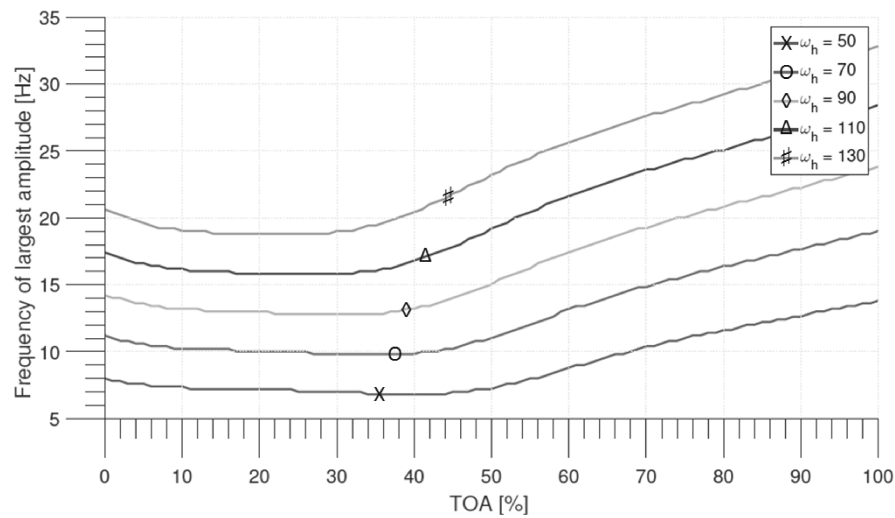

Figure 9: The frequency corresponding to the largest observed amplitude versus TOA for $B = 0.725$ and different values of ω_h ($w_h = 2\pi f_h$).

values of the largest amplitudes were high at low values of TOA and then were steeply decreasing in certain region followed by zone of slow steady decreasing.

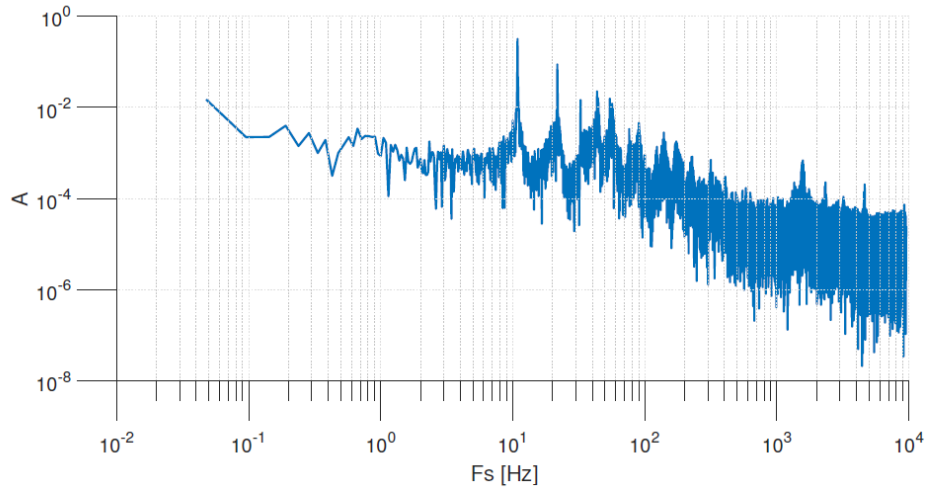

Figure 10: The experimental signal for TOA = 4%, after FFT (A – amplitude, Fs – frequency).

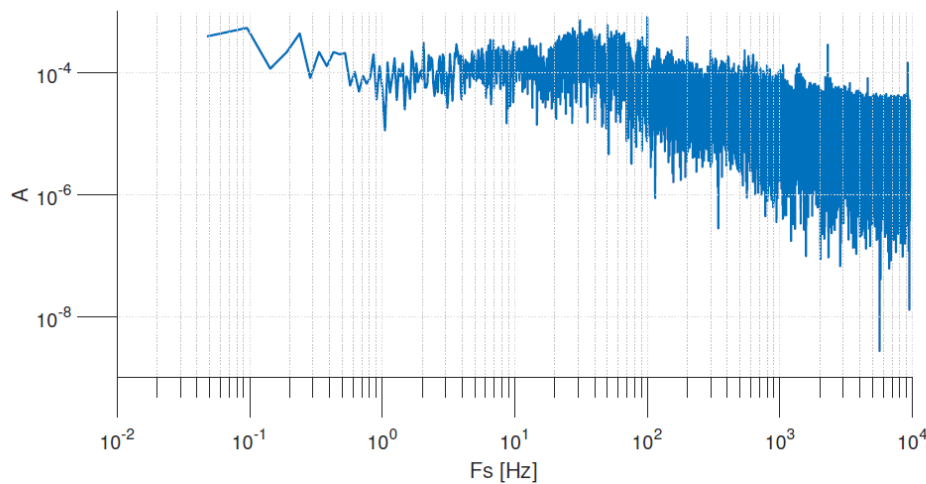

Figure 11: The experimental signal for TOA = 50%, after FFT (A – amplitude, Fs – frequency).

The highest amplitudes observed in Fig. 6 correspond to the surge phenomenon. In this region the damping forces are not strong enough to prevent the pressure oscillation in the compressor, so amplitudes are significant. The region of step decrease of amplitude can be regarded as the border between unstable and sta-

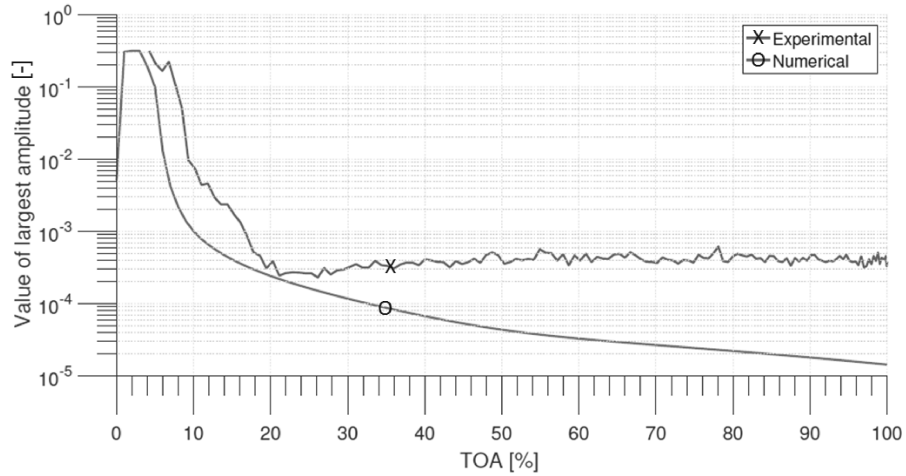

Figure 12: The largest amplitude versus TOA obtained from experiment compared with corresponding numerical results.

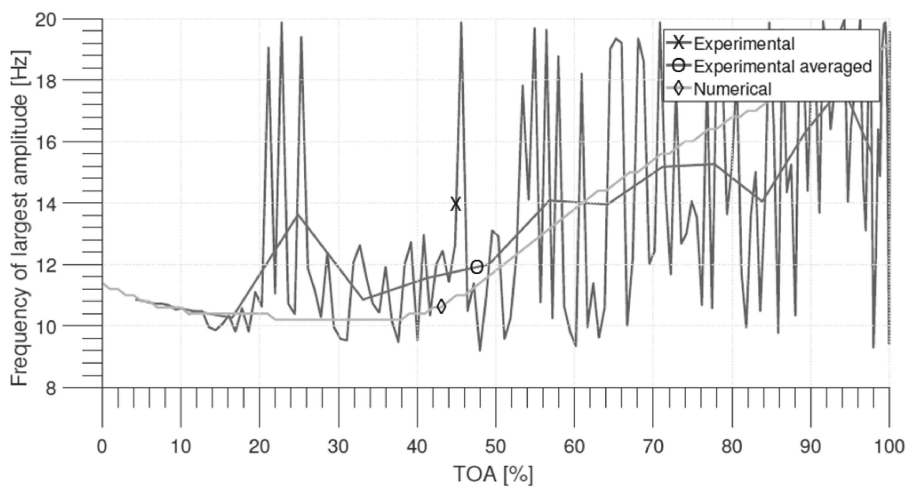

Figure 13: The frequency corresponding to largest amplitude versus TOA obtained from experiment. Line marked with O visualises a general trend computed by averaging the original result (line marked with X) on span of 10 samples. Experimental results are compared with corresponding numerical results.

ble regions of the compressor. Further, slower decrease is caused by increase of damping forces that diminish the influence of perturbations.

Further analysis was devoted to the influence of Greitzer model parameters B

and f_h on the dependencies discussed above. Knowledge of their influence would allow to estimate values of B and f_h by finding the best fit with the curves from experimental pressure signals.

One can easily notice that the higher the value of B the wider the surge zone. This is closely connected with the stability limits discussed in details in [13]. The influence on the frequency at which the maximal amplitude occurs is not clear, so no direct conclusions could be made. The estimation of the value of B parameter based on the stable work of compressor should be an object of further investigation.

Although the influence of f_h on the curves of value of maximal amplitude versus TOA is not significant, one can notice that it strongly influence a positioning of the largest amplitude in the spectrum. With the good accuracy one could state that it only translates the curve vertically. This is important observation as it is enough to know the nature of curve and the frequency at which we observe the largest oscillations at any point of operation to estimate the value of f_h . Although the nature of the curve depends strongly on B parameter, in the operation at TOA < 50% this dependency is weaker, which makes it possible to know the approximate curve shape without prior estimation of B .

The possibility of estimation of Greitzer model parameters by comparison with pressure signals from stable operation of compressor is very important for realisation of active antisurge systems based on Greitzer model. Such systems were proposed by Willems [9,25] and Grapow [19], but their applicability was questionable due to limitations of accuracy of model parameters.

4.2 Comparison with experimental results

At TOA = 4% the frequency at which the peak of oscillation in the numerical result from the unstable operation occurred, matches perfectly the one from experimental signal spectrum. It was expected as the parameters in Greitzer model were chosen such that, they match the amplitude and frequency of oscillation in the deep surge [19]. In the experimental data in stable regime there exist a wide dispersed peak similar to the one shown in numerical results. It occurs, however, at higher frequency.

Similar analysis of the value of the largest amplitude and frequency corresponding to it was done as in case of numerical results. In the experimental data the unstable region was wider than in corresponding numerical results. This can be caused by using two equations model which does not take into account rotating stall which can be the cause of oscillations at the interface between stable and surge regions. The errors in estimation of compressor performance curve, throttle

constant or assumed Greitzer model parameters, could have the other causes.

The analysis of frequency of the largest amplitude versus TOA was complex due to very strong noise in the signal and relatively weak dependency which was sought. The interval of frequencies in which the maximal amplitude was searched was trimmed to only $9 \text{ Hz} < f < 20 \text{ Hz}$. The obtained results, however very noisy, after averaging on span of 10 samples gave general trend similar to this obtained from numerical analysis. The need of trimming and very noisy experimental results question the applicability of perturbed Greitzer model to estimation of f_h and B . Therefore smoothing of the signal or modifying the measurement methodology should be the object of further works in this topic.

5 Summary

In this paper the regularly perturbed Greitzer model was proposed. It can be used to obtain the oscillations spectra even for stable operation of compressor. Comparing them with experimental signals gives the possibility to estimate and adjust the parameters in the Greitzer model for the given system without entering the unstable operation.

The analysis of the results from this method showed that estimation of the Greitzer model parameters is possible. It could be realized by optimization of the parameter values to achieve the best fit of the resulting curve of positioning of the highest amplitude in spectrum for different values of TOA with experimentally obtained one.

The experimental results confirmed the general trends obtained from numerical analysis but before the unknown parameters could be estimated the effort should be made to improve the signal smoothing method or measurement methodology.

Received in July 2016

References

- [1] Emmons H.W., Pearson C.E., Grant H.P.: *Compressor surge and stall propagation*. Trans. ASME **77**(1955), 455–467.
- [2] Moore F.K., Greitzer E.M.: *A theory of post-stall transients in axial compression systems: Part II – Application*. J. Eng. Gas Turb. Power **108**(1986), 2, 231–239.
- [3] Abed E.H., Houpt P.K., Hosny W.M.: *Bifurcation analysis of surge and rotating stall in axial flow compressions*. In: Proc. American Control Conf., 1990, 2239–2246.

- [4] Liaw D., Chang S.: *Bifurcation analysis of a centrifugal compressor*. In: Proc. IEEE Int. Conf. on Systems, Man and Cybernetics, 2011, 1538–1543.
- [5] Greitzer E.M.: *Surge and rotating stall in axial flow compressors – Part I Theoretical compression system model*. J. Eng. Power **98**(1976), 2, 190–198.
- [6] Greitzer E.M.: *Surge and rotating stall in axial flow compressors – Part II: Experimental results and comparison with theory*. J. Eng. Power **98**(1976), 2, 199–211.
- [7] Moore F.K., Greitzer E.M.: *A theory of post-stall transients in axial compression systems: Part I – Development of equations*. J. Eng. Gas Turb. Power **108**(1986), 1, 68–76.
- [8] Moore F.K., Greitzer E.M.: *A theory of post-stall transients in axial compression systems: Part II – Application*. J. Eng. Gas Turb. Power **108**(1986), 2, 231–239.
- [9] Willems F.P.T.: *Modeling and bounded feedback stabilization of centrifugal compressor surge*. PhD thesis, Technische Universiteit Eindhoven, Eindhoven 2000.
- [10] Hansen K.E., Jorgensen P., Larsen P.S.: *Experimental and theoretical study of surge in a small centrifugal compressor*. J. Fluids Eng. **103**(1981), 3, 391–395.
- [11] Meuleman C., Willems F., de Lange R., de Jager B.: *Surge in a low-speed radial compressor*. In: Proc. 43rd Int. Gas Turbine and Aeroengine Cong. ASME, Paper 98-GT-4261998.
- [12] Fink D.A., Cumpsty N.A., Greitzer E.M.: *Surge dynamics in a free-spool centrifugal compressor system*. In: ASME 1991 Int. Gas Turbine and Aeroengine Cong. Exp. ASME, 1991, 001T01A010.
- [13] Liskiewicz G.: *Numerical model of the flow phenomena preceding surge in the centrifugal blower and assessment of its applicability in designing anti-surge devices*. PhD thesis, University of Strathclyde, Lodz University of Technology, Lodz 2014.
- [14] Horodko L.: *Application of time-frequency signal analysis to investigation of unstable operation of radial compressor*. Technical Report 990, Lodz University of Technology, Łódź 2006 (in Polish).
- [15] Yoon S.Y., Lin Z., Goyné C., Allaire P.E.: *An enhanced greitzer compressor model with pipeline dynamics included*. In: American Control Conference (ACC), 2011, 4731–4736.
- [16] Van Helvoirt J., De Jager B.: *Dynamic model including piping acoustics of a centrifugal compression system*. J. Sound Vibration **302**(2007), 1, 361–378.
- [17] Van Helvoirt J., de Jager B., Steinbuch M., Smeulders J.: *Stability parameter identification for a centrifugal compression system*. In: 43rd IEEE Conf. on Decision and Control, CDC. 4, 2004, 3400–3405.
- [18] Willems F. and de Jager B.: *Modeling and control of compressor flow instabilities*. Control Systems **19**(1999), 5, 8–18.
- [19] Grapow F.: *Projekt systemu antypompazowego dla stanowiska dmuchawy odśrodkowej*. BSc thesis, Lodz University of Technology, Łódź 2015 (in Polish).
- [20] Liśkiewicz G., Horodko L., Stickland M., Kryłłowicz W.: *Identification of phenomena preceding blower surge by means of pressure spectral maps*. Exp. Thermal Fluid Sci. **54**(2014), 267–278.
- [21] Garcia D., Stickland M., and Liskiewicz G.: *Dynamical system analysis of unstable flow phenomena in centrifugal blower*. Open Eng. **5**(2015), 1, 332–342.

- [22] Liskiewicz G., Horodko L.: *Time-frequency analysis of the surge onset in the centrifugal blower*. Open Eng. **5**(2015), 1, 299–306.
- [23] Kuz'min V.A. and Khazhuev V.N.: *Measurement of liquid or gas flow (flow velocity) using convergent channels with a witoszynski profile*. Measurement techniques **36**(1993), 3, 288–296.
- [24] Brigham E.O., Morrow R.E.: *The fast Fourier transform*. Spectrum, IEEE **4**(1967), 12, 63–70.
- [25] Willems F., Heemels W.P., De Jager B., Stoorvogel A.A.: *Positive feedback stabilization of centrifugal compressor surge*. Automatica **38**(2002), 2, 311–318.