

Daniel Stępnia^{*}, Jan Surwiło, Piotr Lampart, Mariusz Szymaniak

The analysis of energy and emission indicators of a piston engine supplied by a mixture of biogas

*Institute of Fluid Flow Machinery, Polish Academy of Sciences, Fiszerka 14,
80-231 Gdańsk, Poland*

Abstract

The paper presents the methodology and results of research focused on experimental investigation of combustion of biogas fuels in a combustion piston engine. The study highlights the variability of exhaust gases parameters produced by the engine running in an idle mode and in a generation mode. The experimental analysis includes research about variability of temperature in the cylinders, depending on the composition of fuel used to supply the engine. The qualitative and quantitative analysis of exhaust gases extends on biogas substitutes with different proportions of CH₄ and CO₂. Characteristics of a piston combustion engine were created, including CO, CO₂, NO_x emission indicators, for a range of engine load and fuel composition.

Keywords: Piston combustion engine; Low caloric fuels; Biogas; CO, CO₂, NO_x emission

1 Introduction

During operation of a combustion piston engine the main monitored parameter is the excess air coefficient. It is essential for appropriate opening of throttle valves controlling the flow of fuel mixture. There are other monitored parameters such as exhaust gas temperature, content of O₂, CO_x and NO_x. The latter indicators inform about the degree of burnout and about the process of combustion taking place in the cylinders. Evaluation of the content of CO_x and NO_x is a key issue for the sake of fulfilling emission standards to allow the operation of the power generation unit. In the analysis of energy parameters of the engine, usually generated

^{*}Corresponding Author. Email address: dstepniak@imp.gda.pl

power, efficiency and specific heat consumption for a range of operation of the unit are considered. These quantities result from the construction of the engine, its supply system as well as the measurement and automation system responsible for the control of the combustion process.

At the stage of design of piston combustion engines, both energetic, economic and ecological aspects are taken into account [1–5]. Complex investigations of combustion piston engines, including the quantitative and qualitative analysis of exhaust gases as well as the analysis of energy parameters provide a considerable amount of useful data. They are instrumental in further improvements of existing units and elaboration of new technological solutions, especially in the field of monitoring, control and supply systems. In this paper research is focused on experimental investigation of combustion of biogas fuels to allow their efficient operation for a range of composition of biogas.

2 Experimental facility

The experimental facility raised at IMP PAN consists of two main elements – a group of two piston combustion generation units (ZGT-60/D/MA/PE [Mielec-Diesel] of nominal power $P = 60$ kVA and AG30PO [Autogas] of nominal power $P = 30$ kVA) and a gas mixing/supply system.

2.1 Piston combustion generation unit

A view of a stand-alone electric energy generating unit ZGT-60/D/MA/PE used in the present investigations is presented in Fig. 1. The unit is based on a piston combustion engine of spark ignition connected by clutch with a generator of electric energy. The generator is connected to the grid. However, both grid and island generation is possible. Parameters of the generation unit are gathered in Tab. 1. The engine is supplied from a gas mixing installation, which enables us to obtain fuel of a required composition.

An electronic controller UNIGEN is used for operation and communication with the piston engine generation unit. Modules implemented in the control system enable monitoring and control of operating parameters important for

- control of the ignition system,
- control of the fuel composition and excess air,
- control of the rotational velocity,
- automatic synchronisation with the public electric power network.

Monitoring and diagnostics of the piston engine generation unit was made by the connection RS-232 or wireless connection RJ-45 with the local Ethernet.



Figure 1: Piston combustion generation unit ZGT-60/D/MA/PE

Table 1: Data for piston combustion generation unit ZGT-60/D/MA/PE.

Number of cylinders	6
Power	60 kVA
$\text{tg}\alpha$	40
Nominal rotational velocity	1500 rpm
Operating mode	4 stroke
Ignition	spark

In order to measure the composition of exhaust gases a Testo 330 [6] analyser was used. The connected device allowed for qualitative and quantitative measurements of exhaust gases. The measuring probe was mounted through a coil tube of stainless steel placed in the exhaust gas channel just before the silencer. The probe was tested not to disturb the flow of exhaust gases. Among the monitored quantities were:

- content of O_2 , CO , CO_2 , NO_x ;
- excess air λ ;
- temperature of exhaust gases and air.

2.2 Gas mixing/supply installation

The scheme of the gas mixing/supply installation is illustrated in Fig. 2. By means of portioning and metering appropriate proportions of gases such as methane, hydrogen, carbon monoxide, carbon dioxide and nitrogen, the mixing installation is ready to produce fuel mixtures of variable composition, heating value and flow rate for a required load of the engine. The maximum system capacity is $2 \text{ m}^3/\text{min}$, which refers to the flow rate of syngas of a heating value $6 \text{ MJ}/\text{m}^3$ [1] needed to obtain the nominal power of the engine ZGT-60/D/MA/PE.

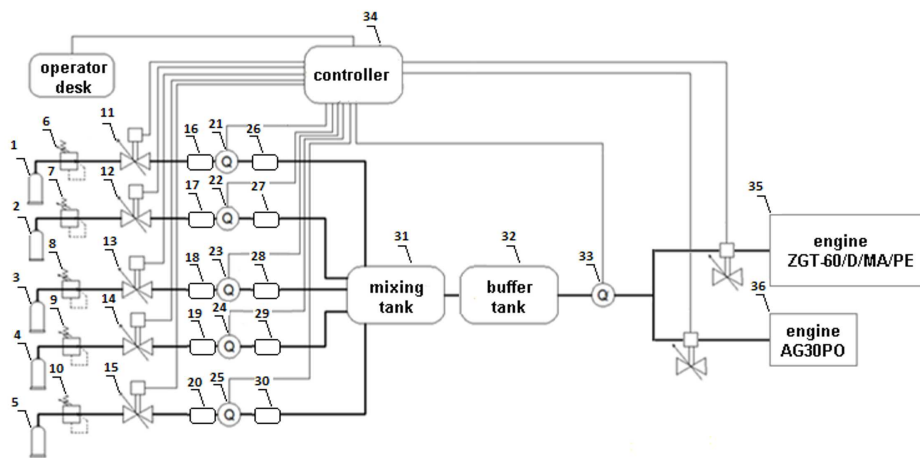

Figure 2: Scheme of the gas mixing/supply system for preparation of low-caloric syngas mixtures: 1–5 – gas pressure vessels 6–10 – valves; 11–15 – reductions, 16–20 – compensation vessels, 21–25 – flow meters, temperature and pressure sensors, 26–30 – compensation vessels, 31 – mixer, 32 – buffer tank, 34 – controller, 35–36 – engines [7].

The installation can be divided into three sections:

- section with gas pressure vessels (Fig. 3),
- section with a heater, cooler and gas mixing tank (Fig. 4),
- section with engines, measuring, control and monitoring system as well as anti-leak/anti-explosion protection system.

The two first sections are located outside of the laboratory building in its close surroundings. The third section is located inside the laboratory building.

The measuring, control and monitoring system is based on National Instruments tools with the dedicated software LabView [8]. Utilisation of this software enables easy reading and processing of acquired data. Its application facilitates the control of operation of control valves, their settings and signals obtained from



Figure 3: Gas pressure vessels section.



Figure 4: Mixer section.

measuring instruments such as flow meters. The control system automatically enforces closure of the valves when the pressures or temperatures exceed critical values, on the other hand in the case of stable operations assures appropriate valve settings to obtain the requires flow rates of particular gases. Additional software compatible with the LabView enables continuous graphical representation of transients of flow parameters and valve settings.

3 Metodology of experimental investigations

Experimental investigations were conducted within several series. In the first series the piston engine generation unit was supplied by pure methane. Then in subsequent sections the engine was supplied by a mixture of methane and carbon dioxide, with an increasing share of the latter from series to series. Thus during the subsequent series the engine was supplied by a biogas substitute with the following compositions of methane and carbon dioxide (volume fractions): 70% CH₄/30% CO₂ – mixture 1 denoted as Biogas 70/30, 60% CH₄/40% CO₂ – mixture 2 denoted as Biogas 60/40, 50% CH₄/ 50% CO₂ – mixture 3 denoted as Biogas 50/50, 40% CH₄/60% CO₂ – mixture 4 denoted as Biogas 40/60, 30% CH₄/70% CO₂ – mixture 5 denoted as Biogas 30/70. Due to the fact that mass flow meters were used in the mixing installation, it was necessary to recalculate volume fractions into mass fractions according to the following formulas:

$$m_i = v_i \mu_i / \mu_m , \quad (1)$$

$$\mu_m = \sum v_i \mu_i , \quad (2)$$

where: m_i – mass fraction of the component i , v_i – volume fraction of the component i , μ_i – molecular weight of the component i , μ_m – molecular weight of the mixture.

For each of the above fuels the piston combustion engine was investigated for an idle run and external load: 11 kW, 17 kW, 22 kW, 28 kW, 38 kW loaded by a series of electric blowers and heaters. Measurements of engine work indicators were made in 5 min intervals. In all measurement series, the control of throttle valve openings was made to obtain a stable value of the excess air ratio $\lambda = 1.32$.

4 Experimental results

An easily discovered tendency is a decreasing temperature in the piston cylinders with the increasing load. For example, for the piston combustion engine generation unit supplied by methane, the change in temperature in cylinder 6 observed during load changes was equal to $\Delta t_6 = 17$ °C. The maximum temperature difference refers to measurements during loads of $P = 11$ kW and $P = 37$ kW. Temperature differences between the idle run and external load of $P = 37$ kW registered in cylinder 1 and 6 are equal to $\Delta t_1 = 56$ °C and $t_6 = 57$ °C, respectively.

Temperatures in the piston cylinders increase with the decreasing caloric value of the biogas fuel. During operation of the piston combustion engine generation unit supplied by Biogas 60/40, the temperature difference in cylinders 1 and 6 between loads $P = 11$ kW and $P = 37$ kW was found to be $\Delta t_1 = 37$ °C and $\Delta t_6 = 38$ °C. The maximum temperature difference obtained between the idle run and external load $P = 37$ kW in cylinders 1 and 6 was equal to $\Delta t_1 = 49$ °C and $\Delta t_6 = 57$ °C, respectively.

Table 2: Temperature in subsequent cylinders supplied by various biogas fuels under different load.

Fuel type	Load	Temperature in cylinders					
		1	2	3	4	5	6
[kW]		[°C]					
Methane	0	661	664	647	670	654	666
	11	615	625	609	625	622	626
	17	617	629	608	626	626	624
	22	615	637	608	625	632	621
	28	612	635	604	625	631	619
	37	605	633	603	622	630	609
Biogas 70/30	0	609	624	602	624	616	618
	11	619	630	604	623	630	622
	17	616	636	610	624	632	626
	22	614	636	606	626	636	622
	28	608	636	605	626	634	614
	37	604	632	600	622	629	607
Biogas 60/40	0	641	650	638	652	644	654
	11	627	644	621	635	643	636
	17	625	649	619	635	648	634
	22	622	646	618	635	646	629
	28	616	641	613	633	642	620
	37	609	636	606	627	638	612
Biogas 50/50	0	654	665	644	663	659	667
	11	638	659	635	651	660	650
	17	630	655	630	645	656	640
	22	624	654	624	642	651	633
	28	619	648	618	635	646	624
	37	608	638	608	627	639	613
Biogas 40/60	0	662	682	657	670	678	676
	11	650	674	646	667	674	657
	18	641	671	646	664	673	653
	22	636	666	637	656	665	642
	28	628	659	628	650	658	634
	37	613	647	615	636	651	619
Biogas 30/70	0	678	696	664	686	695	684
	11	665	692	665	681	690	673
	17	-	-	-	-	-	-
	22	-	-	-	-	-	-
	28	-	-	-	-	-	-
	37	-	-	-	-	-	-

While considering various biogas fuels, the largest temperature difference for an idle run was observed in cylinder 2 between Biogas 30/70 and Biogas 70/30, and was equal to $\Delta t_2 = 72\text{ }^\circ\text{C}$. Comparing the temperature differences for various biogas fuels for a load of $P = 37\text{ kW}$, they are much smaller and do not exceed $\Delta t_2 = 12\text{ }^\circ\text{C}$ observed in cylinder 2 for the supply of the piston combustion engine generation unit by Biogas 40/60 and Biogas 70/30, see Figs. 5 and 6.

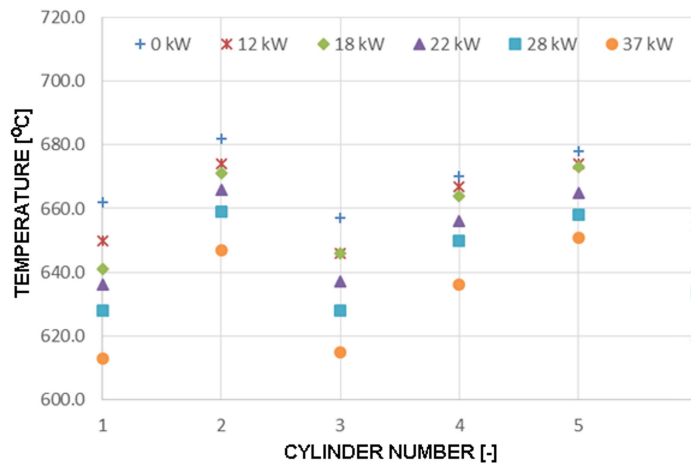

Figure 5: Temperature in subsequent cylinders supplied by biogas 40/60 under different load.

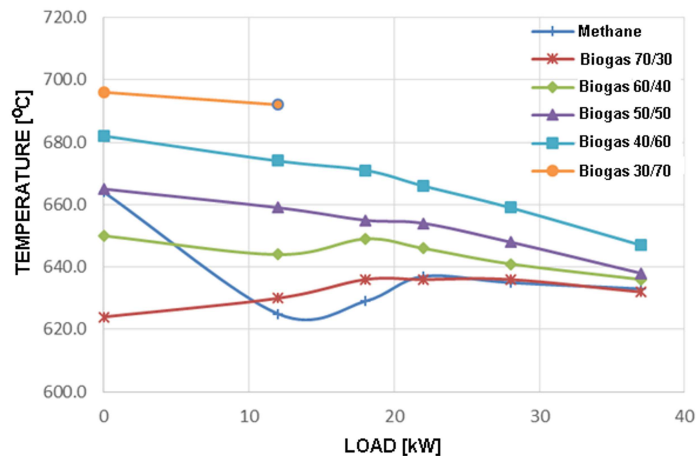

Figure 6: Temperature in cylinder 2 for various biogas fuels under different load.

Currently small energy instalations based on combustion of fuels do not need to obey emission limits (only large professional installations). However, they have standards set so as to calculate the equivalent emissions from combustion of natural gas, that is $1.52 \text{ g/m}^3 \text{ NO}_x$ and $0.3 \text{ g/m}^3 \text{ CO}$ for installations smaller than 0.5 MW (see a report of KOBiZE National Centre for Balance and Management of Emissions [9]). The equivalent emissions from an energy installation fed by biogas should be calculated as proportional to those from natural gas.

The content of NO_x in exhaust gases decreases with the increasing content of CO_2 . This is due to the fact that a large amount of this inert gas dilutes the fuel-air mixture in the cylinder. The investigated engine is not turbocharged, therefore the amount of air is smaller than for a rich fuel-air mixture. Also a smaller amount of nitrogen participates in the process of combustion. Additionally, a large amount of heat obtained during combustion is used for heating CO_2 . Therefore fewer nitrogen atoms are oxidised. The content of NO increases with the engine load. The maximum registered amount of NO is equal to 300 ppm at load $P = 37 \text{ kW}$ for the supply of engine by a high-caloric Biogas 70/30. During operation of the piston combustion engine unit at an idle run, this value is much lower and does not considerably change with the fuel type between 10–30 ppm, see Fig. 7.

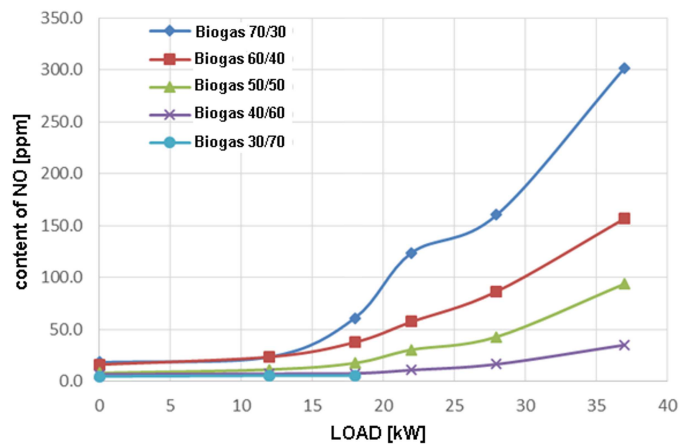

Figure 7: Content of NO in exhaust gases under different load.

The largest value of CO content in the exhaust gases is recorded at 775 ppm for the maximum load and high-caloric biogas. The CO content decreases with the increasing content of CO_2 in the fuel. Above a certain value of load, the CO content increases with the increasing engine load and with the caloric value of the biogas fuel. This tendency is not clear for very low loads. The minimum value

Table 3: Measured working parameters of the piston engine supplied by various biogas fuels.

Fuel type	Load [kW]	Exhaust gas temp. [°C]	% CO ₂	CO [ppm]	NO [ppm]	λ [-]
Biogas 70/30	0	32.06	5.18	666.56	18.32	1.33
	11	22.97	5.12	572.97	23.57	1.32
	17	34.29	5.15	682.18	60.96	1.32
	22	32.12	5.02	726.88	123.81	1.31
	28	33.76	5.08	720.18	160.18	1.32
	37	37.46	5.12	774.33	301.49	1.32
Biogas 60/40	0	22.56	5.10	661.57	16.19	1.32
	11	22.97	5.12	572.97	23.57	1.32
	17	24.71	5.15	600.78	37.63	1.33
	22	26.40	5.08	626.50	57.36	1.32
	28	28.97	5.15	645.82	86.56	1.32
	37	31.79	5.16	678.99	156.56	1.33
Biogas 50/50	0	23.63	5.10	629.36	8.07	1.32
	11	25.37	5.09	561.09	11.43	1.32
	17	27.68	5.14	539.57	17.65	1.32
	22	29.67	5.05	557.69	30.44	1.31
	28	32.60	5.19	555.67	42.91	1.33
	37	36.46	5.18	612.05	93.77	1.33
Biogas 40/60	0	23.49	5.10	666.27	6.71	1.32
	11	27.15	5.09	553.48	7.34	1.32
	17	29.15	5.16	516.11	7.75	1.33
	22	33.61	5.19	481.21	10.88	1.33
	28	35.52	5.17	474.16	16.57	1.33
	37	39.19	5.15	499.50	34.96	1.32
Biogas 30/70	0	26.61	5.11	743.28	4.85	1.32
	11	29.70	5.05	609.31	5.58	1.31
	17	34.60	5.09	571.58	5.68	1.32
	22	-	-	-	-	-
	28	-	-	-	-	-
	37	-	-	-	-	-

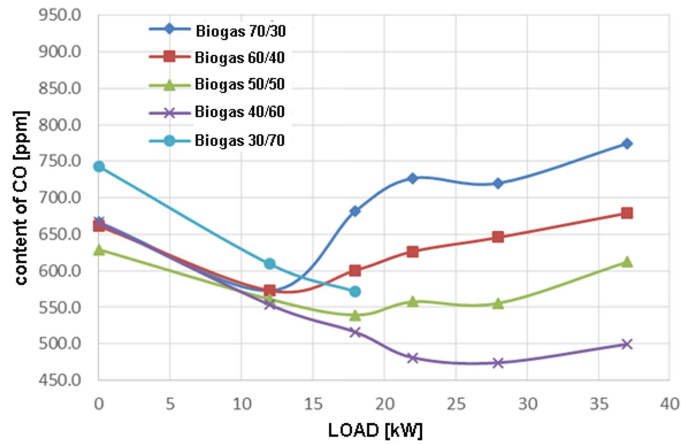

Figure 8: Content of CO in exhaust gases under different load

does not fall below 500 ppm. For the idle run the content of CO increases for poor mixtures, however it is also high for the rich mixture. For the idle run the engine is controlled by an idle run controller, other than the main controller, which may affect the obtained results. To sum up, the contents of NO and CO basically increase with the increasing caloric value of the biogas mixture and increasing engine load.

The engine worked property for biogas mixtures 1 (Biogas 70/30), 2 (Biogas 60/40), 3 (Biogas 50/50) and 4 (Biogas 40/60). During the engine supply by a poor mixture (Biogas 30/70) beginning from the load of $P = 22$ kW an ignition instability was observed. The combustion was terminated in two or three cylinders. Rotational velocity of the engine was reduced, affecting the frequency of the generated voltage. Further operation of the piston engine generation unit was not allowed by its controller.

5 Conclusions

Experimental investigations of a piston combustion engine supply by biogas reveal that the temperature in the cylinder decreases with the increasing engine load and increasing caloric value of the biogas fuel. The engine was tested to work property for biogas mixtures 1 (Biogas 70/30), 2 (Biogas 60/40), 3 (Biogas 50/50), and 4 (Biogas 40/60) in the assumed range of load. For a poor biogas mixture (Biogas 30/70) operation of the unit was terminated at the load of 22 kW.

The composition of biogas fuel and the engine load have also an effect on the composition and purity of exhaust gases. Basically, above a certain value of load the content of NO and CO increase with the increasing engine load and caloric value of the biogas fuel. The largest content of NO in exhaust gases was obtained for a rich mixture (Biogas 70/30) and it decreases with the decreasing caloric value of fuel. This value depends on the piston engine load and changes between 20–300 ppm. A similar trend is observed for the content of CO above a certain level of load. For the rich mixture it equals 600–800 ppm and decreases with lean mixtures. The conclusion of the paper is that with the decreasing caloric value of biogas fuel (increasing content of inert gas – CO₂) the emissions of NO and CO expressed in ppm decrease, which is a positive effect of biogas application.

Received in December 2016

References

- [1] Stępniaak D., Surwiło J.: *Analysis of energy and emission indicators during supply of a piston engine with syngas*. Rep. IMP PAN 535/2015, Gdańsk 2015 (in Polish).
- [2] Stępniaak D., Surwiło J.: *Wxperimental investigations of combustion of syngas in a piston engine*. Rep. IMP PAN 412/2015, Gdańsk 2015 (in Polish).
- [3] Sahoo B., Sahoo N., Saha U.: *Effect of H₂:CO₂ ratio in syngas on the performance of a dual fuel diesel engine operation*. Appl. Therm. Eng. **49**(2011), 139–146.
- [4] Przybyła G., Szlęak A., Ziółkowski Ł.: *The lean mixture combustion of simulated producer gas in SI engine*. J. KONES Powertrain Transport **20**(2013), 3, 331–338.
- [5] Przybyła G., Szlęak A., Ziółkowski Ł.: *Assessment of the performance of a small capacity SI engine fuelled with model lean mixture of biogas*. Int. J. Thermodyn. **16**(2014), 179–188.
- [6] www.testo.com.pl, (accessed: 19 Mar. 2016).
- [7] Skarpetowski B., Stępniaak D., Koronowicz J., Lampart P., Jędrzejewski Ł.: *Design of a syngas station for supply of an ignition piston engine*. Rep. IMP PAN 817/2012, Gdańsk 2012 (in Polish).
- [8] www.ni.com/labview (accesed: 5 Nov. 2016).
- [9] https://krajowabaza.kobize.pl/docs/male_kotly.pdf (accesed: 5 Nov. 2016).